

○ Powder coating

Dimensions: Height: 1,300 mm
Width: 300 mm
Length: 13,000 mm

Standard colours: RAL 3000,
RAL 9002/9010



○ Wet lacquer finishing

Dimensions: No limitations
Standard colours: Primed in red/brown



○ Zinc (external)

Dimensions: No limitations



○ Shipment

Shipment inside and outside Germany. You can choose between: Delivery by open trailer and lift truck or Delivery by closed trailer.



Illustration.: Open semi-trailer
with truck-mounted forklift

We take customer proximity literally!

Each of our eight branches has all the departments required to implement your safety concepts – including sales, planning, installation and customer services.

CALANBAU prides itself on being an excellent partner, ensuring close cooperation, reliability and top performance. We have already won over a large number of companies.

We're sure that you too will be impressed!

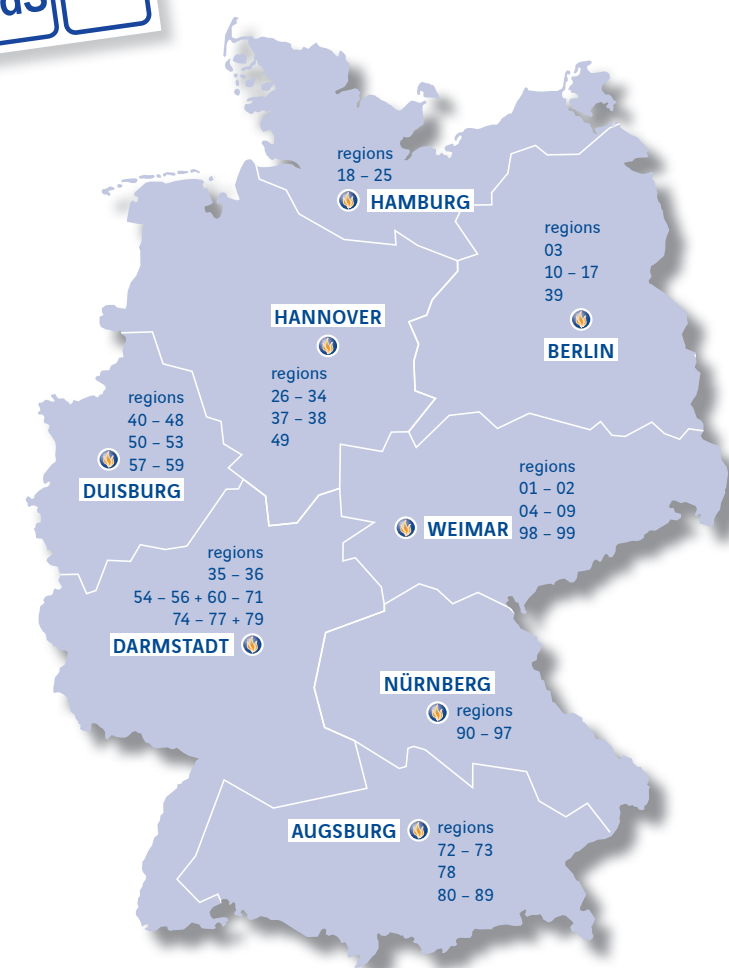

Our branches:



CALANBAU-GFA Feuerschutzanlagen GmbH
Wenderter Straße 12
31157 Sarstedt
T: +49(0)5066 808-238
F: +49(0)5066 808-239
Internet: www.fire-protection-solutions.com
E-Mail: info@fire-protection-solutions.com

Output 04/2020

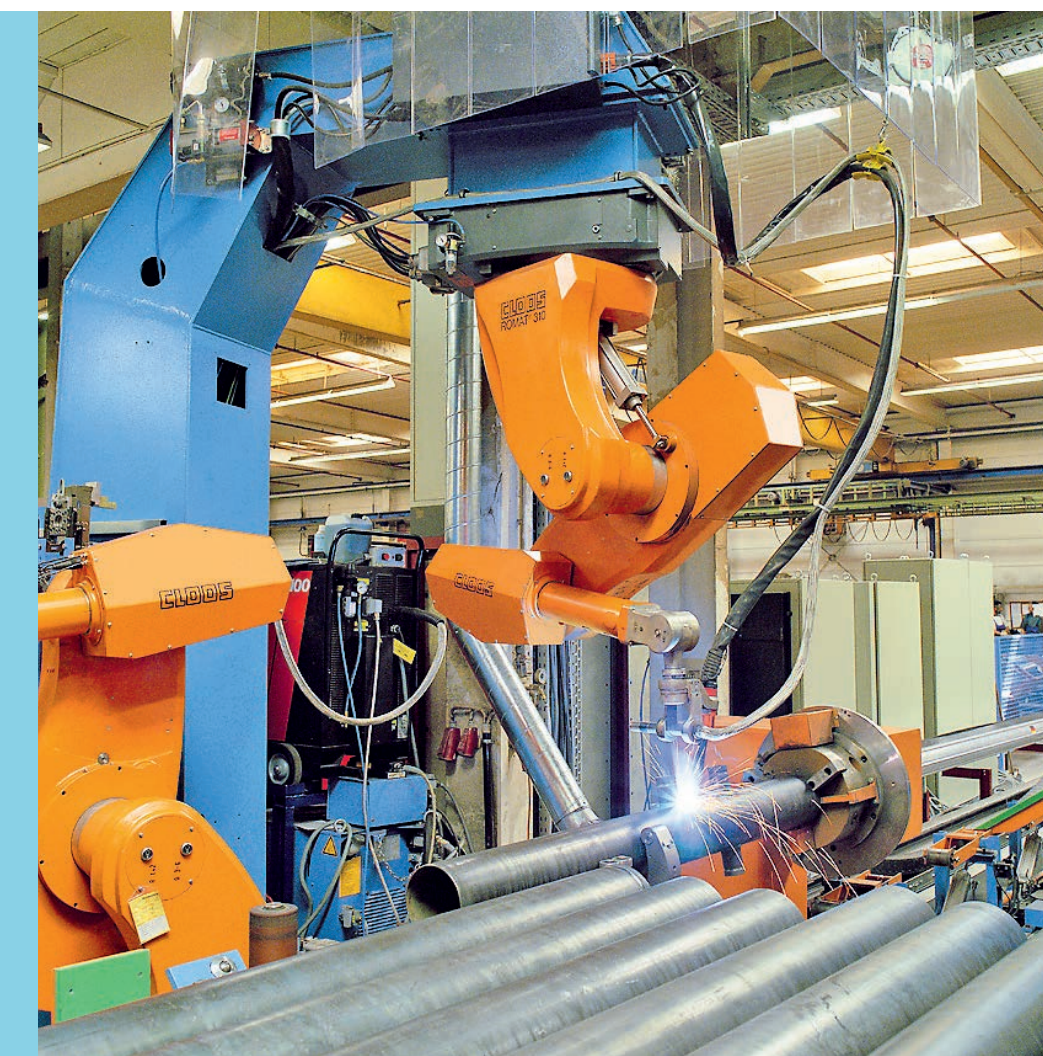

Technical data sheet

Standard pipes to DIN EN 10220 |
10217 (DIN 2458 | 1626)

Part no.	Diameter	Thickness
9216 1005	42,40 mm	2,60 mm
9216 1025	48,30 mm	2,60 mm
9216 1045	60,30 mm	2,60 mm
9216 0007	76,10 mm	2,60 mm
9216 0013	88,90 mm	2,90 mm
9216 0022	114,30 mm	3,20 mm
9216 0027	139,70 mm	3,60 mm
9216 0030	168,30 mm	4,00 mm
9216 0034	219,10 mm	4,50 mm
9216 1155	273,00 mm	6,30 mm
9216 1161	323,90 mm	7,10 mm

Hanover branch
Wenderter Straße 12 | 31157 Sarstedt
T. +49(0)5066 808-0 | F. +49(0)5066 808-549
E-mail: nl.hannover@calanbau.de

Darmstadt branch
Gerhart-Hauptmann-Straße 20 | 64347 Griesheim
T. +49(0)6155 8741-0 | F. +49(0)6155 8741-599
E-mail: nl.darmstadt@calanbau.de

Augsburg branch
Peterhofstraße 3 | 86438 Kissing
T. +49(0)8233 7919-0 | F. +49(0)8233 7919-649
E-mail: nl.augsburg@calanbau.de

Weimar branch
Österholzstraße 9 | 99428 Grammetal
T. +49(0)3643 2474-0 | F. +49(0)3643 2474-699
E-mail: nl.weimar@calanbau.de

Berlin branch
Pankstraße 8 | 13127 Berlin
T. +49(0)30 414782-0 | F. +49(0)30 414782-749
E-mail: nl.berlin@calanbau.de

Duisburg branch
Hohenbudberger Str. 33 | 47829 Krefeld
T. +49(0)2151 78250-0 | F. +49(0)2151 78250-29
E-mail: nl.duisburg@calanbau.de

Nuremberg branch
Wiesbadener Straße 25 | 90427 Nürnberg
T. +49(0)911 950669-0 | F. +49(0)911 950669-849
E-mail: nl.nuernberg@calanbau.de

Hamburg branch
Pinkertweg 20 | 22113 Hamburg
T. +49(0)40 7909079-0 | F. +49(0)40 7909079-949
E-mail: nl.hamburg@calanbau.de

Solutions you can rely on when speed is vital.

**Our know-how –
for your safety.**

Material

- Common construction steel (St 37, S 235)

Pipe dimensions

- 42.4 to 76.1 mm

Pipe lengths

- 1,500 to 13,000 mm

Outlets

- Diameter of threaded outlets 3/8" to 1 1/4"
- Depending on pipe diameter
- Length of threaded outlets 17 to 70 mm
- Diameter of grooved outlets 42.4 to 76.1 mm depending on pipe diameter
- Length of grooved outlets 50 to 110 mm

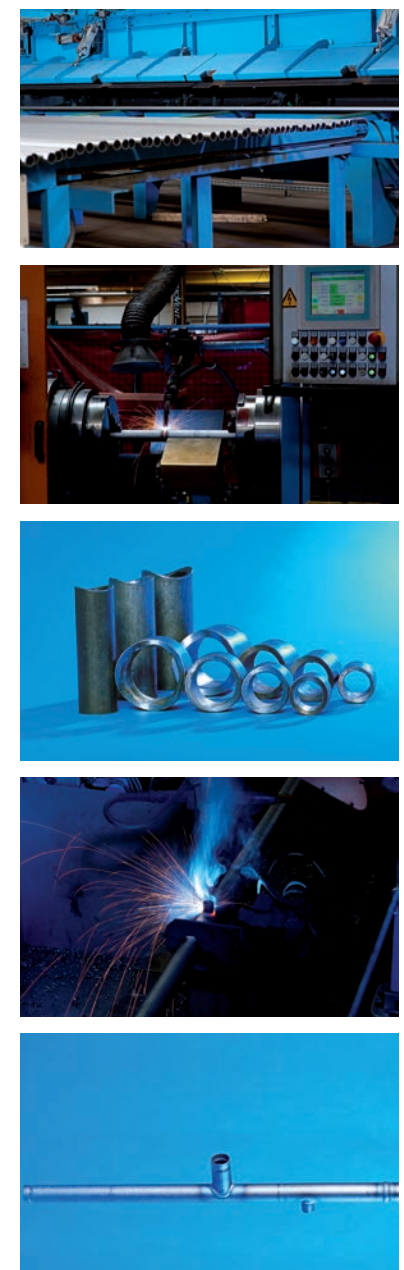
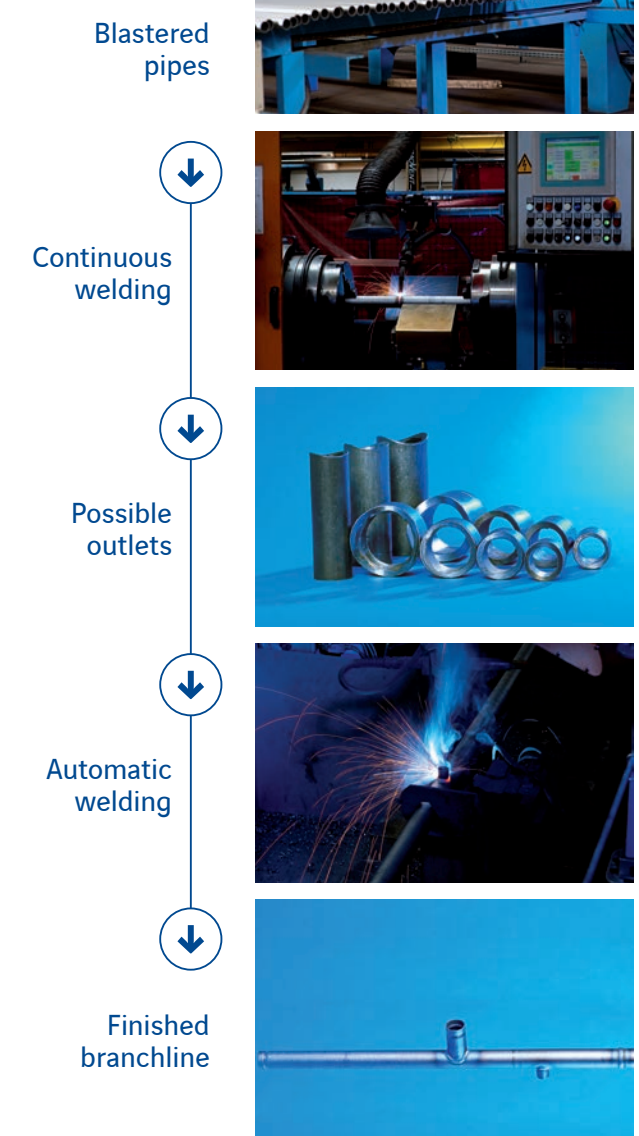

Material

- Common construction steel (St 37, S 235)

Pipe dimensions

- 76.1 to 219.1 mm

Pipe lengths

- 1,500 to 10,000 mm

Outlets

- Diameter of threaded outlets 1" to 2"
- Depending on pipe diameter
- Length of threaded outlets 45 to 53 mm
- Diameter of grooved outlets 42.4 to 139.7 mm depending on pipe diameter, but always one diameter smaller than the basic pipe
- Length of grooved outlet 80 mm

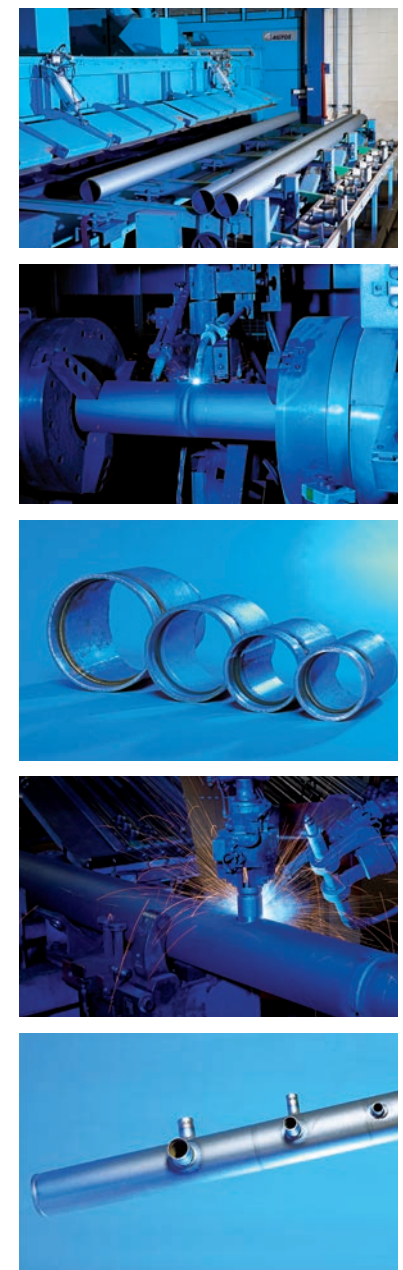
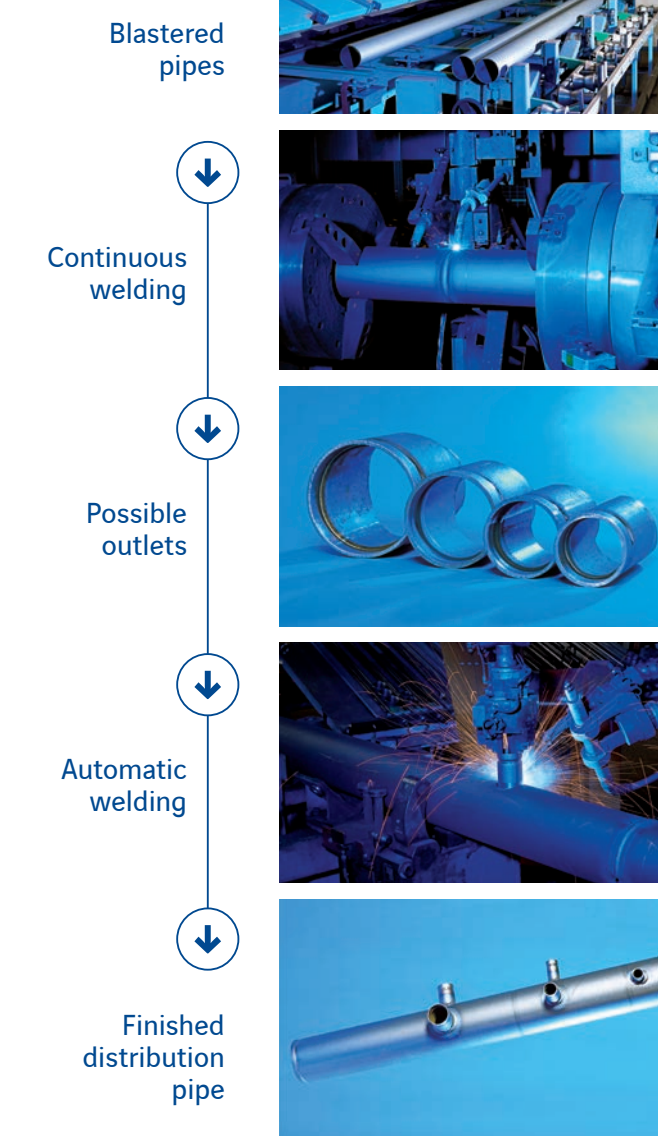

Material

- Common construction steel (St 37, S 235)
- High-grade steel (1.4541)

Pipe dimensions

- 33.7 to 508.0 mm

Pipe lengths

- Up to 13,000 mm

Outlets

- Diameter of threaded outlets 3/8" to 4"
- Diameter of grooved outlets 42.4 to 508.0 mm
- Flange and coupling joints
- All standard welding fittings

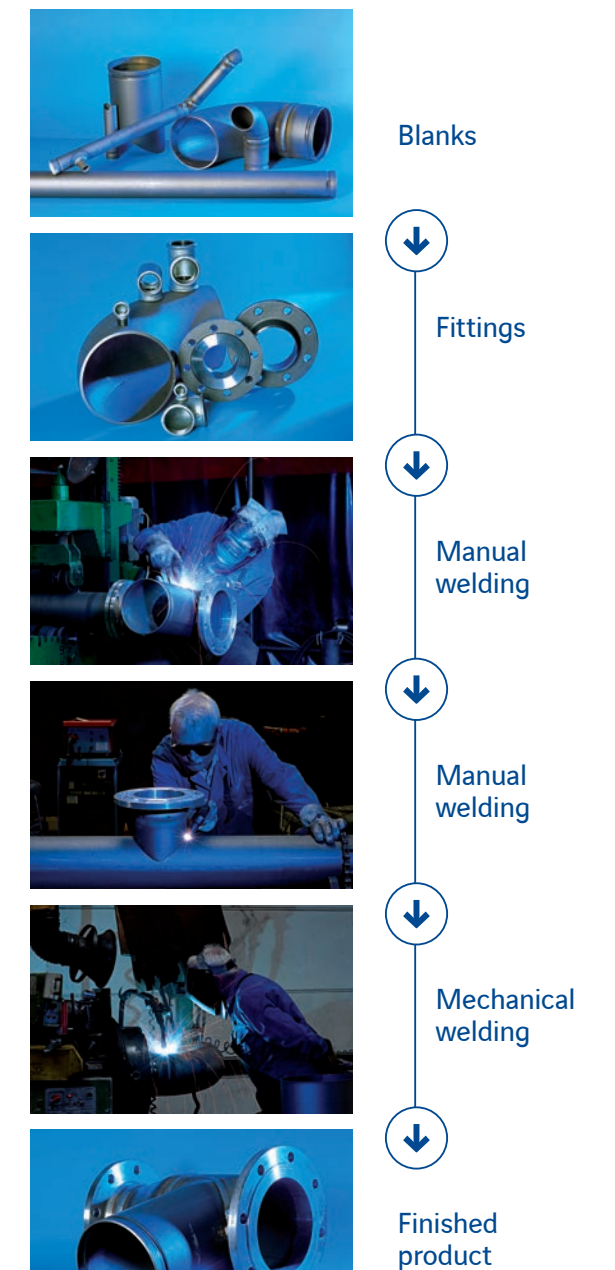
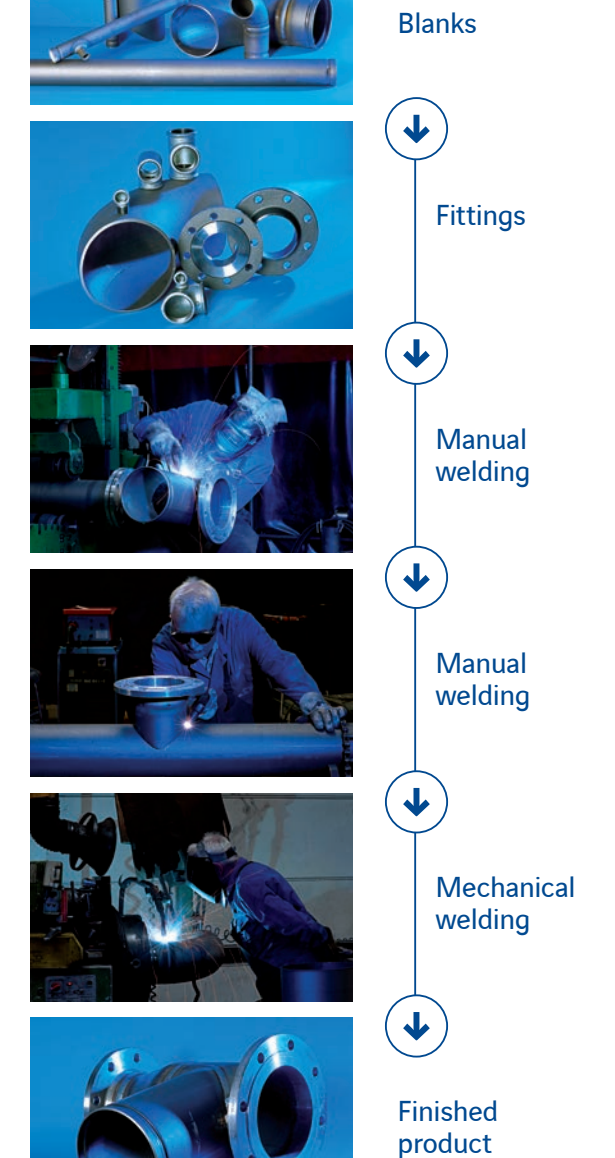

Technical data sheet

Automatic branchline prefabrication

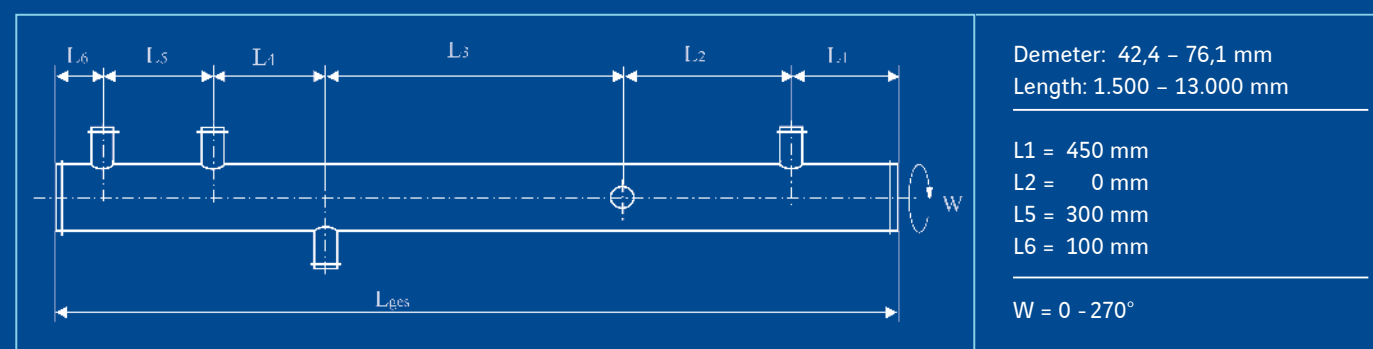

Technical data sheet

Automatic distribution pipe prefabrication

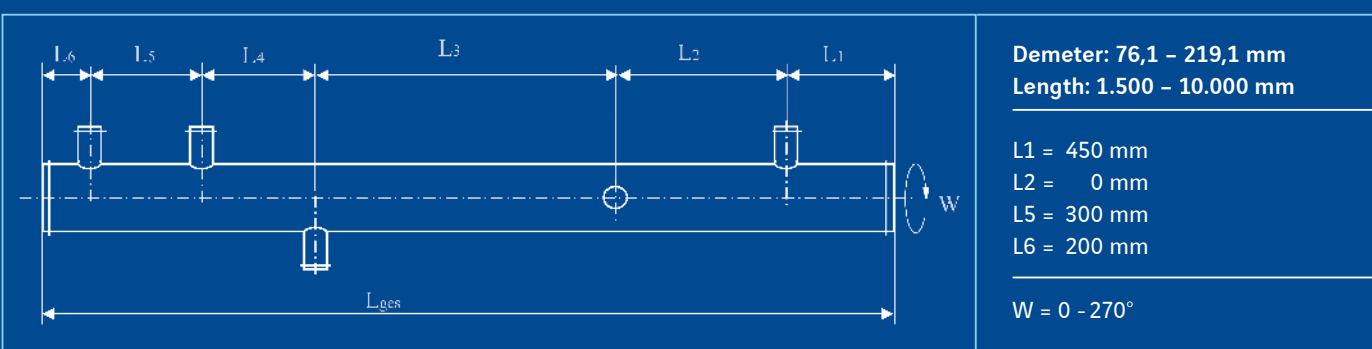

Technical data sheet

to DIN EN 10241, with thread to DIN EN 10226 | 1

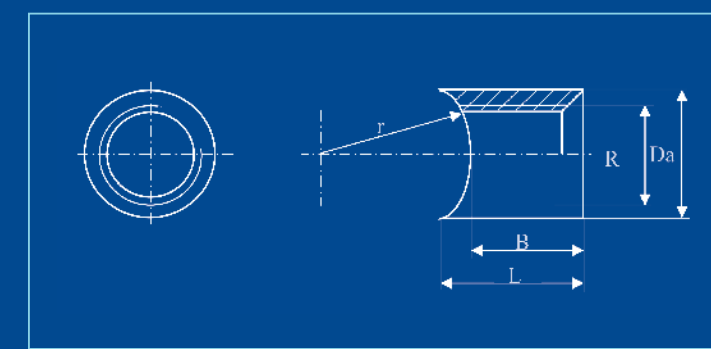

Part no.	R	Diameter	Length (B)	
5105 0711	3/8"	21,3 mm	13,0 mm	kurz
5105 0713	1/2"	26,9 mm	16,0 mm	
5105 0715	3/4"	31,8 mm	14,0 mm	
5105 0717	1"	39,7 mm	20,0 mm	
5105 0701	3/8"	21,3 mm	24,0 mm	normal
5105 0703	1/2"	26,9 mm	30,0 mm	
5105 0705	3/4"	31,8 mm	30,0 mm	
5105 0707	1"	39,7 mm	37,0 mm	
5105 0721	3/8"	21,3 mm	68,0 mm	lang
5105 0723	1/2"	26,9 mm	68,0 mm	
5105 0725	3/4"	31,8 mm	68,0 mm	